

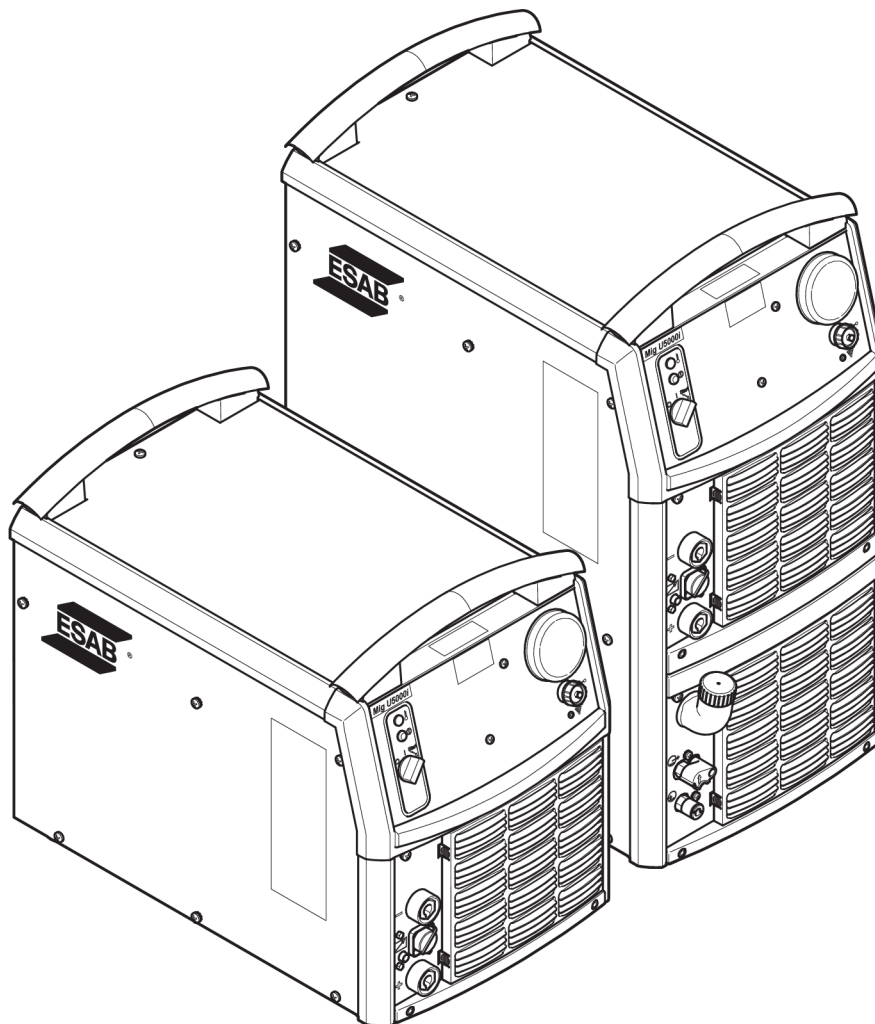

Aristo®

Mig 5000i WeldCloud™ **400 V**



Instruction manual



EU DECLARATION OF CONFORMITY

According to:

The Low Voltage Directive 2014/35/EU;
The RoHS Directive 2011/65/EU;

The EMC Directive 2014/30/EU;
The Ecodesign Directive 2009/125/EC

Type of equipment

Arc welding power source

Type designation

Mig 5000i / 5000iw WeldCloud from serial number OP444 YY XX XXXX
Mig U5000i / U5000iw WeldCloud from serial number OP444 YY XX XXXX

X and Y represents digits, 0 to 9 in the serial number, where YY indicates year of production.

Brand name or trademark

ESAB

Manufacturer or his authorised representative established within the EEA

ESAB AB
Lindholmsallén 9, Box 8004, SE-402 77 Göteborg, Sweden
Phone: +46 31 50 90 00, www.esab.com

The following EN standards and regulations in force within the EEA has been used in the design:

EN IEC 60974-1 :2018/A1 :2019	Arc Welding Equipment - Part 1: Welding power sources
EN IEC 60974-2: 2019	Arc Welding Equipment - Part 2: Liquid cooling systems
EN IEC 60974-3:2019	Arc Welding Equipment - Part 3: Arc striking and stabilizing devices
EN 60974-10:2014/A 1 :2015,	Arc Welding Equipment - Part 10: Electromagnetic compatibility (EMC) requirements
EN 303 446-2.	Electromagnetic Compatibility (EMC) standard for combined and/or integrated radio and non-radio equipment; Part 2: Specific conditions for equipment intended to be used in industrial locations
EN 301 489-17 V3.2.0	Part 17: Specific conditions for Broadband Data Transmission Systems
EN 301 489-19 V2.1.0	Part 19: Specific conditions for GPS
E.N 301 489-52 V1 .1.0	Part 52: Specific conditions for Cellular Communication
EN 301 489-1 V2.2.0	Part 1: Common technical requirements
EU no. 2019/1784	Ecodesign requirements for welding equipment pursuant to Directive 2009/125/EC

Additional Information:

Restrictive use, Class A equipment, intended for use in locations other than residential.
Mig U5000(w) and U5000i(w) WeldCloud are part of the ESAB Aristo product family.

By signing this document, the undersigned declares as manufacturer, or the manufacturer's authorised representative established within the EEA, that the equipment in question complies with the safety and environmental requirements stated above.

Place/Date

Gothenburg
2024-10-18

Signature

Peter Burchfield
General Manager, Equipment Solutions

1	SAFETY	4
1.1	Meaning of symbols	4
1.2	Safety precautions	4
2	INTRODUCTION	8
2.1	Equipment	8
3	TECHNICAL DATA	9
4	INSTALLATION	11
4.1	Lifting instructions	11
4.2	Placing	11
4.3	Mains power supply	12
4.4	Terminating resistor	12
4.5	Connection of multiple wire feed units	12
5	OPERATION	15
5.1	Connections and control devices	15
5.2	Turning on the power source	16
5.3	Fan control	16
5.4	Overheating protection	16
5.5	Cooling unit	16
5.6	Remote control unit	16
5.7	WeldCloud™ unit	17
6	MAINTENANCE	18
6.1	Daily	18
6.2	If necessary	18
6.3	Every year	19
7	TROUBLESHOOTING	20
8	ORDERING OF SPARE PARTS	21
	DIAGRAM	22
	ORDERING NUMBERS	24
	SPARE PARTS LIST	25
	ACCESSORIES	26

1 SAFETY

1.1 Meaning of symbols

As used throughout this manual: Means Attention! Be Alert!

**DANGER!**

Means immediate hazards which, if not avoided, will result in immediate, serious personal injury or loss of life.

**WARNING!**

Means potential hazards which could result in personal injury or loss of life.

**CAUTION!**

Means hazards which could result in minor personal injury.

**WARNING!**

Before use, read and understand the instruction manual and follow all labels, employer's safety practices and Safety Data Sheets (SDSs).



1.2 Safety precautions

Users of ESAB equipment have the ultimate responsibility for ensuring that anyone who works on or near the equipment observes all the relevant safety precautions. Safety precautions must meet the requirements that apply to this type of equipment. The following recommendations should be observed in addition to the standard regulations that apply to the workplace.

All work must be carried out by trained personnel well-acquainted with the operation of the equipment. Incorrect operation of the equipment may lead to hazardous situations which can result in injury to the operator and damage to the equipment.

1. Anyone who uses the equipment must be familiar with:
 - its operation
 - location of emergency stops
 - its function
 - relevant safety precautions
 - welding and cutting or other applicable operation of the equipment
2. The operator must ensure that:
 - no unauthorised person is stationed within the working area of the equipment when it is started up
 - no-one is unprotected when the arc is struck or work is started with the equipment
3. The workplace must:
 - be suitable for the purpose
 - be free from drafts

4. Personal safety equipment:
 - Always wear recommended personal safety equipment, such as safety glasses, flame-proof clothing, safety gloves
 - Do not wear loose-fitting items, such as scarves, bracelets, rings, etc., which could become trapped or cause burns
5. General precautions:
 - Make sure the return cable is connected securely
 - Work on high voltage equipment **may only be carried out by a qualified electrician**
 - Appropriate fire extinguishing equipment must be clearly marked and close at hand
 - Lubrication and maintenance must **not** be carried out on the equipment during operation

**WARNING!**

Arc welding and cutting can be injurious to yourself and others. Take precautions when welding and cutting.

**ELECTRIC SHOCK - Can kill**

- Install and ground the unit in accordance with instruction manual.
- Do not touch live electrical parts or electrodes with bare skin, wet gloves or wet clothing.
- Insulate yourself from work and ground.
- Ensure your working position is safe

**ELECTRIC AND MAGNETIC FIELDS - Can be dangerous to health**

- Welders having pacemakers should consult their physician before welding. EMF may interfere with some pacemakers.
- Exposure to EMF may have other health effects which are unknown.
- Welders should use the following procedures to minimize exposure to EMF:
 - Route the electrode and work cables together on the same side of your body. Secure them with tape when possible. Do not place your body between the torch and work cables. Never coil the torch or work cable around your body. Keep welding power source and cables as far away from your body as possible.
 - Connect the work cable to the workpiece as close as possible to the area being welded.

**FUMES AND GASES - Can be dangerous to health**

- Keep your head out of the fumes.
- Use ventilation, extraction at the arc, or both, to take fumes and gases away from your breathing zone and the general area.

**ARC RAYS - Can injure eyes and burn skin**

- Protect your eyes and body. Use the correct welding screen and filter lens and wear protective clothing.
- Protect bystanders with suitable screens or curtains.

**NOISE - Excessive noise can damage hearing**

Protect your ears. Use earmuffs or other hearing protection.



MOVING PARTS - Can cause injuries

- Keep all doors, panels, guards, and covers closed and securely in place.
- Have only qualified people remove covers for maintenance and troubleshooting as necessary.
- Keep hands, hair, loose clothing and tools away from moving parts.
- Reinstall panels or covers and close doors when service is finished and before starting the unit.



FIRE HAZARD

- Sparks (spatter) can cause fire. Make sure that there are no inflammable materials nearby.
- Do not use on closed containers.



HOT SURFACE - Parts can burn

- Do not touch parts bare handed.
- Allow cooling period before working on equipment.
- To handle hot parts, use proper tools and/or insulated welding gloves to prevent burns.



CAUTION!

This product is solely intended for arc welding.



WARNING!

Do not use the power source for thawing frozen pipes.



CAUTION!

Class A equipment is not intended for use in residential locations where the electrical power is provided by the public low-voltage supply system. There may be potential difficulties in ensuring electromagnetic compatibility of class A equipment in those locations, due to conducted as well as radiated disturbances.

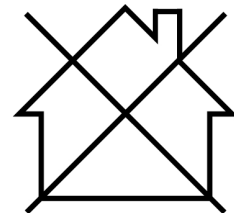

NOTE!

Dispose of electronic equipment at the recycling facility!

In observance of European Directive 2012/19/EC on Waste Electrical and Electronic Equipment and its implementation in accordance with national law, electrical and/or electronic equipment that has reached the end of its life must be disposed of at a recycling facility.

As the person responsible for the equipment, it is your responsibility to obtain information on approved collection stations.

For further information contact the nearest ESAB dealer.



ESAB has an assortment of welding accessories and personal protection equipment for purchase. For ordering information contact your local ESAB dealer or visit us on our website.

2 INTRODUCTION

The **Mig 5000i WeldCloud™** is a MIG/MAG welding power source.

The manual is valid for:

- Mig 5000i with WeldCloud™ unit



NOTE!

These instructions describe a Mig 5000i WeldCloud™ with a cooling unit.

The power source is intended for use with the wire feed unit RobustFeed U6, RobustFeed U82, and RobustFeed Pulse.

Serial No	MIG	TIG	MMA	Gouging	Software version
Before OP444	x	x	x	x	1.90P
From OP444	x				1.90Q

The power source **Mig 5000i WeldCloud™** is combined with U8₂ and provides a control box which enables wireless monitoring.

ESAB accessories for the product can be found in the "ACCESSORIES" chapter of this manual.

For more information about feed units, refer to the Instruction manuals.

For more information about WeldCloud™, refer to the Quick start guide.

2.1 Equipment

The power source is supplied complete with:

- An instruction manual
- Terminating resistor
- 5 m return cable

Instruction manuals in other languages can be downloaded from the Internet: www.esab.com

3 TECHNICAL DATA

Mig 5000i WeldCloud™	
Mains voltage	400 V ±10%, 3~ 50/60 Hz
Mains supply	S _{scmin} 14.54 MVA Z _{max} 0.011 Ω
Primary current	
I _{max} MIG/MAG (GMAW)	37 A
No-load power demand when in the energy-saving mode 6.5 min. after welding	
MIG (GMAW)	36 W
Voltage/current range	
MIG/MAG (GMAW)	8 - 60 V / 16 - 500 A
Permissible load at MIG/MAG (GMAW)	
60 % duty cycle	500 A / 39 V
100% duty cycle	400 A / 34 V
Power factor at maximum current (I ₂) MIG	0.90
Efficiency at maximum current (I ₂)	
MIG (GMAW)	86 %
Open-circuit voltage U₀ max	
MIG/MAG (GMAW) without VRD function 1)	72 - 88 V
MIG/MAG (GMAW), VRD function deactivated 2)	59 V
VRD function activated 2)	< 35 V
Operating temperature	-10 to +40 °C (14 to 104 °F)
Transportation temperature	-20 to +55 °C (-4 to 131 °F)
Dimensions l × w × h without cooling unit	625 × 394 × 496 mm (24.6 × 15.5 × 19.6 in.)
with cooling unit	625 × 394 × 776 mm (24.6 × 15.5 × 30.6 in.)
Continual sound pressure at no-load	<70 db (A)
Weight without cooling unit	79 kg (174 lb)
with cooling unit	99 kg (218 lb)
Insulation class transformer	H
Enclosure class	IP23
Application class	S

1) Valid for power sources without VRD specification on the rating plate.

2) Valid for power sources with VRD specification on the rating plate. The VRD function is explained in the instruction manual for the control panel.

Duty cycle

The duty cycle refers to the time as a percentage of a ten-minute period that you can weld or cut at a certain load without overloading. The duty cycle is valid for 40 °C / 104 °F, or below.

Enclosure class

The **IP** code indicates the enclosure class, i.e. the degree of protection against penetration by solid objects or water.

Equipment marked **IP23** is intended for indoor and outdoor use.

Application class

The symbol **S** indicates that the power source is designed for use in areas with increased electrical hazard.

Mains supply, $S_{sc\ min}$

Minimum short circuit power on the network in accordance with IEC 61000-3-12.

Mains supply, Z_{max}

Maximum permissible line impedance of the network in accordance with IEC 61000-3-11.

Cooling unit	
Cooling power	2.0 kW at 40 °C (104 °F) temp. difference and flow 1.0 l/min (0.26 us gal/min)
Coolant	50 % water / 50 % mono-ethylen glycol
Coolant quantity	5.5 l (1.45 us gal)
Maximum water flow	2.0 l/min (0.53 us gal)
Maximum number of water-cooled welding torches that may be connected	Two MIG welding torches

4 INSTALLATION

The installation must be carried out by a professional.







NOTE!

Mains supply requirements

This equipment complies with IEC 61000-3-12 provided that the short-circuit power is greater than or equal to S_{scmin} at the interface point between the user's supply and the public system. It is the responsibility of the installer or user of the equipment to ensure, by consultation with the distribution network operator if necessary, that the equipment is connected only to a supply with a short-circuit power greater than or equal to S_{scmin} . Refer to the technical data in the TECHNICAL DATA chapter.

4.1 Lifting instructions

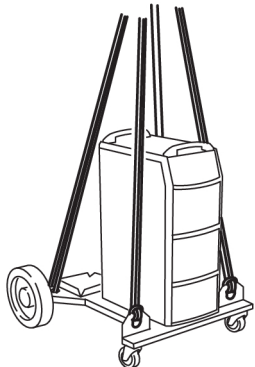
Power source	Trolley and power source	Trolley 2 and power source
	<div data-bbox="608 842 979 999" style="border: 1px solid black; padding: 5px; margin-bottom: 10px;">  </div> 	<div data-bbox="1011 842 1383 999" style="border: 1px solid black; padding: 5px; margin-bottom: 10px;">  </div> 

4.2 Placing

Position the welding power source such that its cooling air inlets and outlets are not obstructed.

4.3 Mains power supply

Check that the unit is connected to the correct mains power supply voltage, and that it is protected by the correct fuse sizes.

A protective earth connection must be made, in accordance with regulations. Rating plate with supply connection data

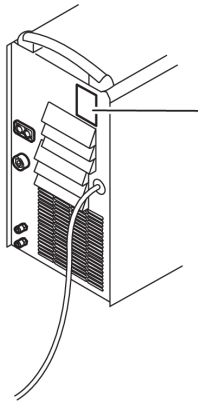

Rating plate with supply connection data

Recommended fuse sizes and minimum cable areas

Mig 5000i WeldCloud™	400 V 3~ 50 Hz
Mains voltage	400 V
Mains cable area, mm ²	4G6
Phase current, $I_{1\text{eff}}$	27 A
Fuse	
Anti-surge	25 A
Type C MCB	32 A



NOTE!

The mains cable areas and fuse sizes as shown above are in accordance with Swedish regulations. For other regions, supply cables must be suitable for the application and meet local and national regulations.

4.4 Terminating resistor

In order to avoid communication interference, the ends of the CAN bus must be fitted with terminating resistors.

One end of the CAN bus is at the control panel, which has an integral terminating resistor. The other end at the power source must be fitted with the terminating resistor, as shown on the right.

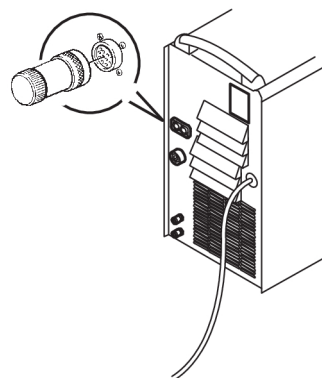

4.5 Connection of multiple wire feed units

With control unit U8 and wire feed units without control panel it is possible to manage up to 4 wire feed units from one power source.

It is possible to choose between the following connections:

- 1 MIG-torch (Universal power source required)
- 2 MIG/MAG-torches
- 3 MIG-torches (Universal power source required)
- 4 MIG-torches

When welding with water-cooled MIG-torches on all wire feed units, it is recommended to connect a separate cooling unit for the 2 extra torches. We recommend connecting the torches in parallel.

Two wire feed units

A connection kit is required when connecting two wire feed units, see chapter "ACCESSORIES".

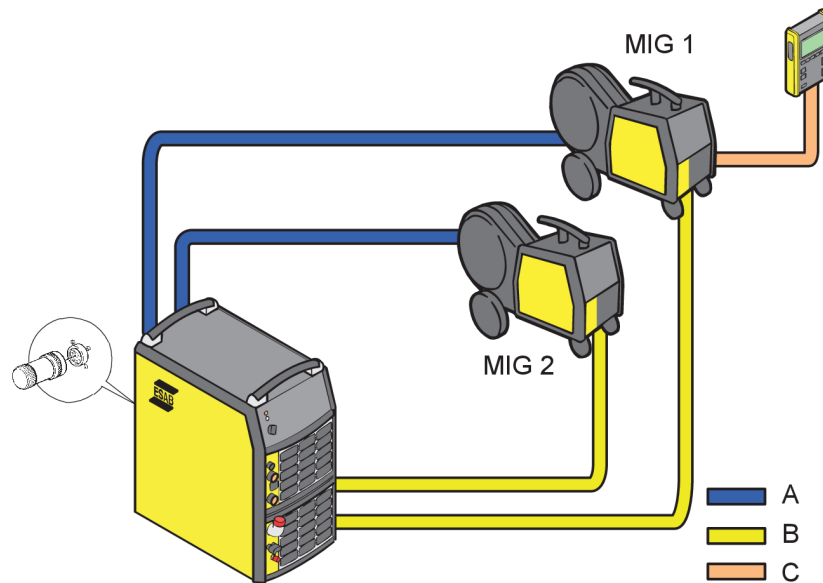

- A. Water connection
- B. Welding current connection
- C. Control box connection

Four wire feed units

Two connection kits and an extra cooling unit are required when connecting four wire feed units, see chapter "ACCESSORIES".

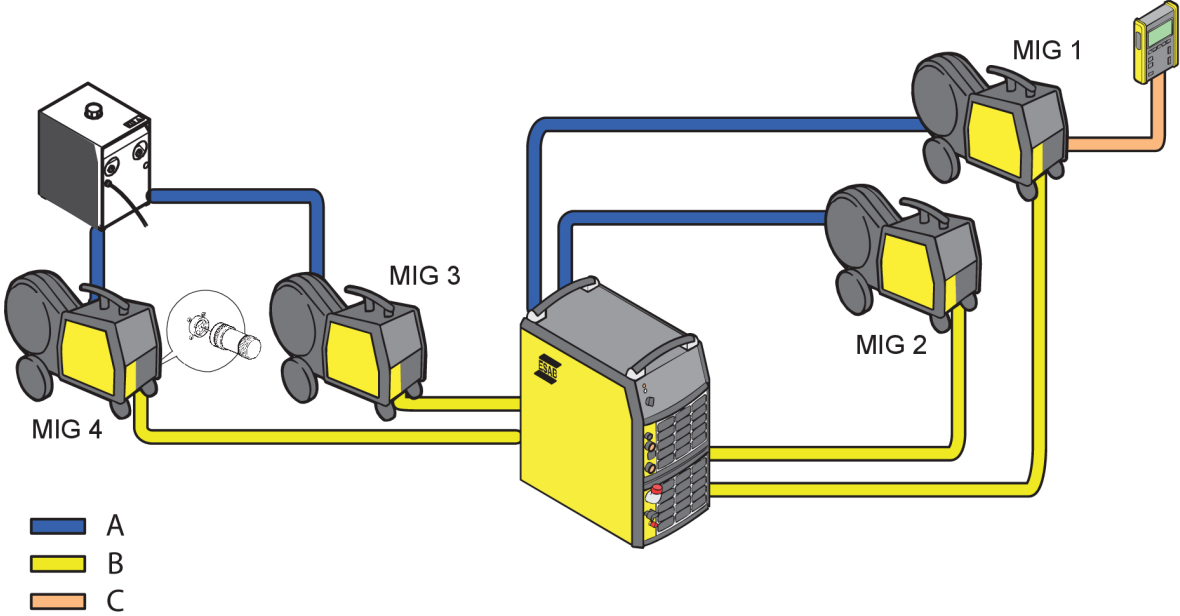

- A. Water connection
- B. Welding current connection
- C. Control box connection

5 OPERATION

General safety regulations for handling the equipment can be found in the "SAFETY" chapter of this manual. Read it through before you start using the equipment!

5.1 Connections and control devices

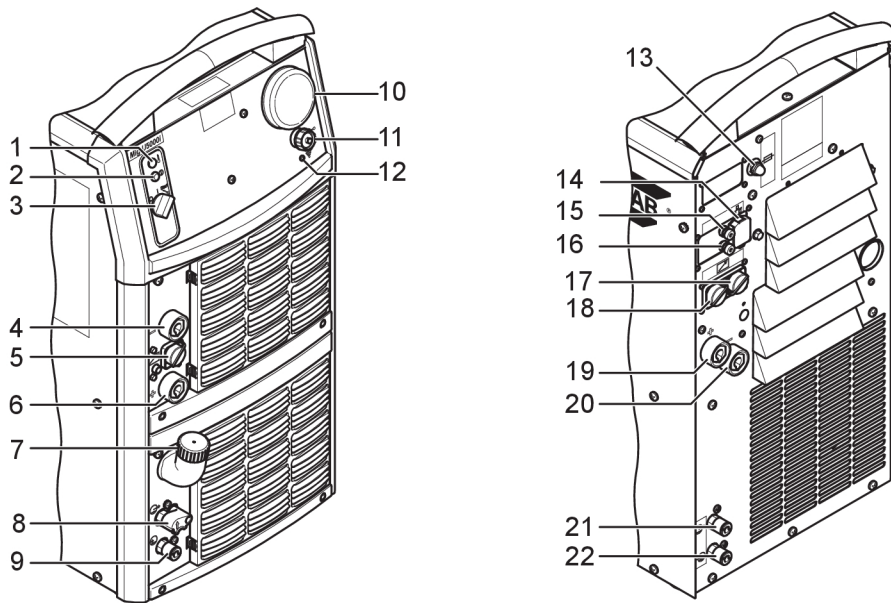

- | | |
|---|--|
| 1 Orange indicating lamp - Overheating | 12 Red indicating lamp –Wifi Connectivity |
| 2 White indicating lamp - Power supply ON | 13 Fuse for supply voltage for feeder unit, 42 V |
| 3 Main power supply switch, 0 / 1 / START | 14 WeldCloud™ version: Connection for Ethernet |
| 4 Connection (-) for return cable | 15 Measure outlet screw terminal - RED (+) |
| 5 Connection for remote control | 16 Measure outlet screw terminal - BLACK (-) |
| 6 Connection (+) for welding current cable | 17 Connection for control cable to the wire feed unit or for the terminating resistor |
| 7 Cooling water filler | 18 Connection for control cable to the wire feed unit or for the terminating resistor |
| 8 Connection with ELP* for cooling water to the torch - BLUE | 19 Connection (+) for welding current cable to the wire feed unit (MIG) |
| 9 Connection for cooling water from the torch - RED | 20 Connection (-) for the return cable (MIG) |
| 10 WeldCloud™ version: Antenna | 21 Connection for cooling water to the wire feed unit - BLUE |
| 11 WeldCloud™ version: USB Connectivity | 22 Connection for cooling water from the wire feed unit - RED |

5.2 Turning on the power source

Turn on the mains power by turning switch (7) to the "START" position. Release the switch, and it will return to the "1" position.

If the mains power supply should be interrupted while welding is in progress, and then be restored, the power source will remain de-energised until the switch is again turned manually to the "START" position.

Turn the unit off by turning the switch to the "0" position.

Whether in the event of a loss of power supply or of turning the power source off in the normal manner, welding data will be stored so that it is available next time the unit is started.

5.3 Fan control

The power source fans continue to run for 6.5 minutes after welding has stopped, and the unit switches to energy-saving mode. They start again when welding restarts.

The fans run at reduced speed for welding currents up to 180 A, and at full speed for higher currents.

5.4 Overheating protection

The power source has three thermal overload trips which operate if the internal temperature becomes too high, interrupting the welding current and lighting the orange indicating lamp on the front of the unit. They reset automatically when the temperature has fallen.

5.5 Cooling unit

To ensure problem-free operation, the installation height from the cooling unit to the welding torch must be max. 7 m. Heights in excess of this can cause problems, such as long starting times, air bubbles, vacuums, etc.

If an installation height in excess of 7 m is required, we recommend an installation kit comprising a non-return valve and a solenoid valve, refer to chapter "ACCESSORIES". Once these valves have been installed, the hose package must be horizontal during the initial startup so that everything fills with water. Then raise the wire feed unit and hose package to the high height. Continued safe operation at installation heights of up to 12 m can now commence.

Function when welding

To start welding, the welder presses the welding torch trigger switch. The power source turns on and starts the wire feed and the cooling water pump.

To stop welding, the welder releases the welding torch trigger switch. Welding ceases, but the cooling water pump continues to run for 6.5 minutes, after which the unit switches to energy-saving mode.

Water flow guard

The water flow guard interrupts the welding current in the event of loss of coolant, and displays an error message on the control panel. The water flow guard is an accessory.

5.6 Remote control unit

The program version in U8 should be 1.20 or higher. Power sources with integral control panels should have program version 1.21 or higher, in order for the remote control to function correctly.

When the remote control unit is connected, the power source and wire feed unit are in remote control mode; the buttons and knobs are blocked. The functions can only be adjusted via the remote unit.

If the remote control unit is not to be used, the remote control unit must be disconnected from the power source / wire feed unit, as otherwise it will remain in remote control mode.

For more information about the operation of the remote control unit, see the operating instructions for the control panel.

5.7 WeldCloud™ unit

The WeldCloud™ unit connects the welding power source with a local WeldCloud™ server through Wi-Fi or Wired LAN. The WeldCloud™ unit is equipped with GPS to track the location of the welding power source. It also has Bluetooth connectivity to enable connection with 3rd party input devices, for example a Bluetooth enabled barcode/QR scanner.

The WeldCloud™ unit Wi-Fi is enabled at power up of the power source. It will start as a hotspot that appears as an available Wi-Fi network. After establishing connection, it is possible to access the web interface of the power source for a one-time set-up. After set-up and restart, the power source will be visible in WeldCloud™. For more information about the WeldCloud™ unit and features, see the WeldCloud™ instruction manual.

6 MAINTENANCE



NOTE!

Regular maintenance is important for safe and reliable operation.

Only those persons who have appropriate electrical knowledge (authorised personnel) may remove the safety plates to connect or carry out service, maintenance or repair work on welding equipment.



CAUTION!

All warranty undertakings from the supplier cease to apply if the customer attempts any work to rectify any faults in the product during the warranty period.

6.1 Daily

Carry out the following maintenance every day.

- Check that all cables and connections are fault free. Tighten if necessary and replace any defective parts.
- Check the water level and water flow, top up with coolant if necessary.

6.2 If necessary

- Regularly check that the power source is not clogged with dirt. Clogged or blocked air inlets and outlets result in overheating
- Clean the dust filter
 - Remove the fan grille with the dust filter (1).
 - Swing out the grille (2).
 - Release the dust filter (3).
 - Blow the filter clean with compressed air (reduced pressure).
 - Replace the filter with the finer mesh on the side against the grille (2) (out from the power source).
 - Replace the fan grille with the dust filter.
- Top up with coolant

ESAB's ready mixed coolant is recommended for use. See chapter "ACCESSORIES".

 - Top up with coolant until it covers half the inlet pipe.

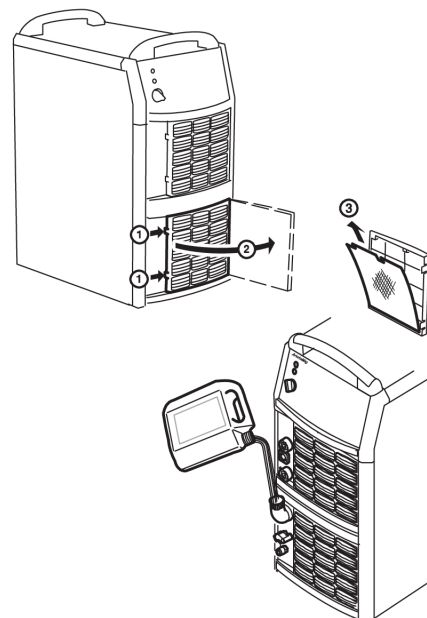

NOTE!

Coolant must be topped up if connecting a welding torch or connection cables that are 5 m in length or longer. When adjusting the water level by topping up, the coolant hose does not need to be disconnected.



CAUTION!

The coolant must be handled as chemical waste.

6.3 Every year

Carry out the following maintenance at least once a year.

- Clean off any dirt and dust. Blow the power source clean with dry compressed air (reduced pressure).
- Change the coolant and clean the hoses and water reservoir with clean water.
- Check seals, cables and connections. Tighten if necessary and replace any defective parts.

7 TROUBLESHOOTING

Try these recommended checks and inspections before sending for an authorised service technician.

Type of fault	Action
No arc.	<ul style="list-style-type: none">• Check that the mains power supply switch is turned on.• Check that the welding current supply and return cables are correctly connected.• Check that the correct current value is set.
Welding current is interrupted during welding.	<ul style="list-style-type: none">• Check whether the thermal overload trips have operated (indicated by the orange lamp on the front panel).• Check the main power supply fuses.
The thermal overload trips operate frequently.	<ul style="list-style-type: none">• Check to see whether the air filters are clogged.• Make sure that you are not exceeding the rated data for the power source (i.e. that the unit is not being overloaded).
Poor welding performance.	<ul style="list-style-type: none">• Check that the welding current supply and return cables are correctly connected.• Check that the correct current value is set.• Check that the correct wire is being used.• Check the main power supply fuses.

8 ORDERING OF SPARE PARTS



CAUTION!

Repair and electrical work should be performed by an authorised ESAB service technician. Use only ESAB original spare and wear parts.

Mig 5000i WeldCloud™ and Mig 5000iw WeldCloud™ are designed and tested in accordance with the international and European standards **IEC/EN 60974-1/-2** and **EN 60974-10**.

It is the obligation of the service unit which has carried out the service or repair work to make sure that the product still conforms to the mentioned standards.

Spare parts and wear parts can be ordered through your nearest ESAB dealer, see [esab.com](https://www.esab.com). When ordering, please state product type, serial number, designation and spare part number in accordance with the spare parts list. This facilitates dispatch and ensures correct delivery.

DIAGRAM

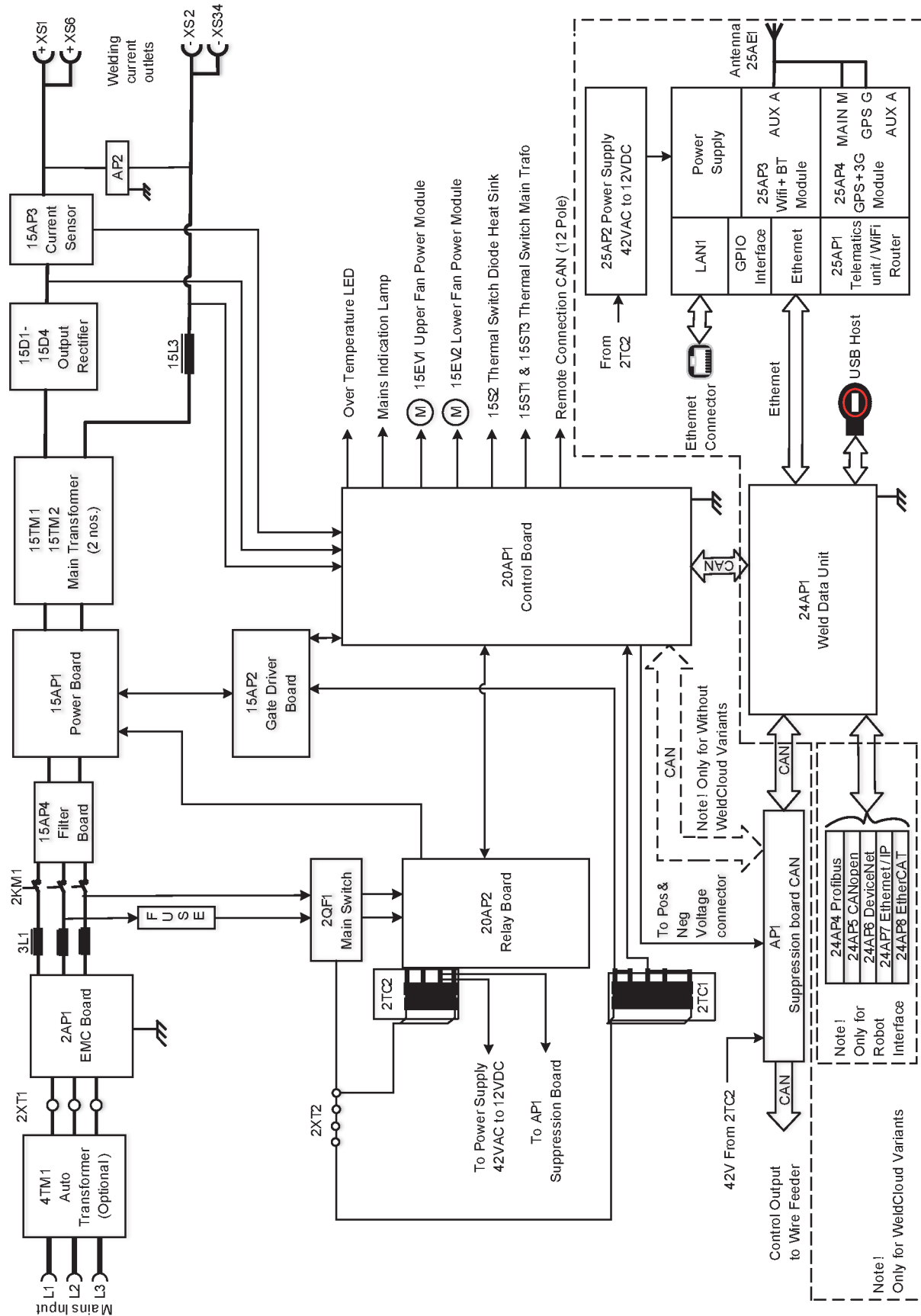

Cooling unit

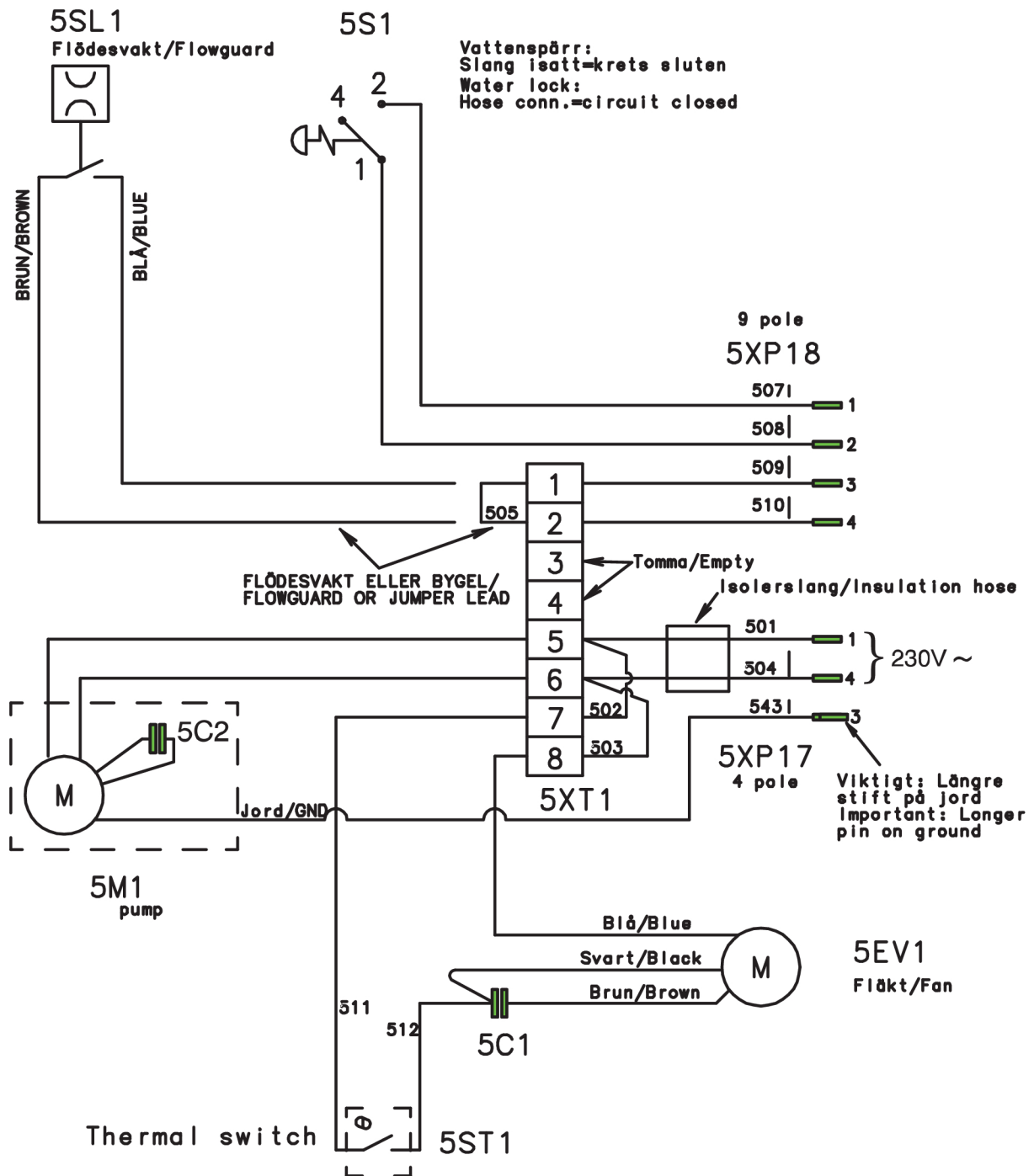

ORDERING NUMBERS

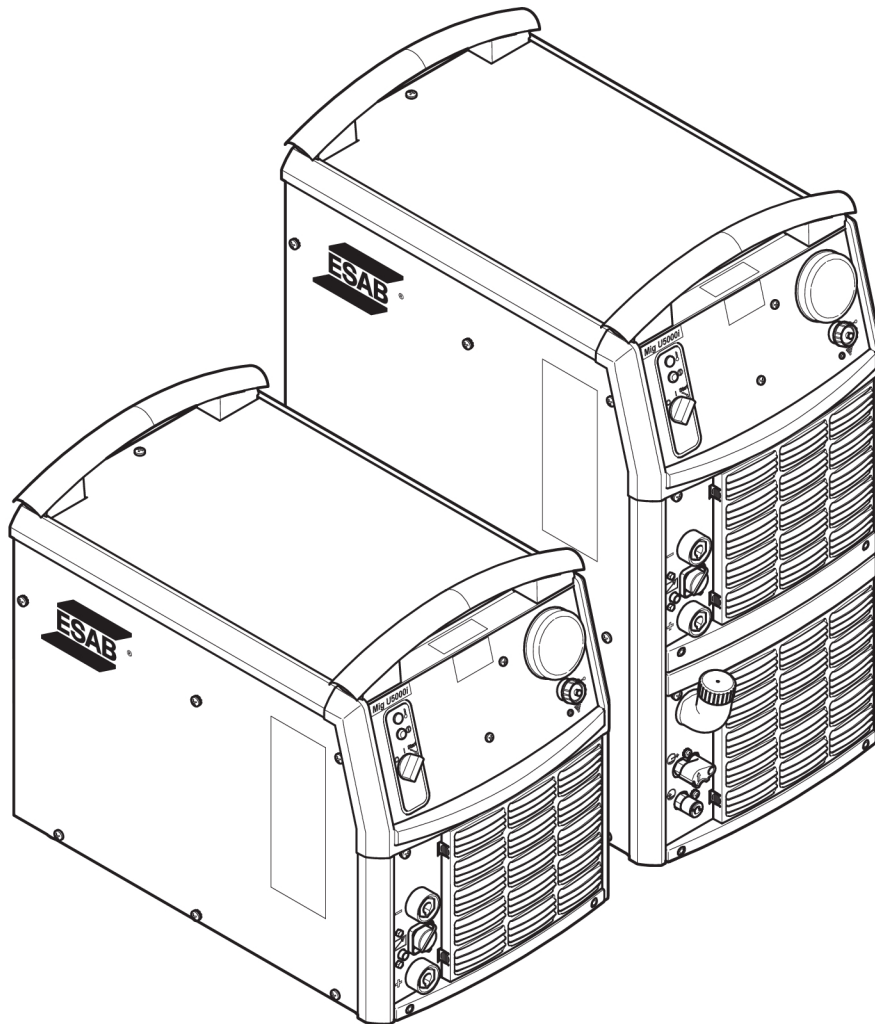

Ordering no.	Denomination	Product	Note
0445 400 880	Welding power source	Mig 5000i WeldCloud™, 400 V	
0445 400 881	Welding power source	Mig 5000iw WeldCloud™, 400 V	With cooling unit
0459 839 018	Spare parts list	Mig 5000i, Mig U5000i, Mig 5000i WeldCloud™, Mig U5000i WeldCloud™	



Technical documentation is available on the Internet at: www.esab.com

SPARE PARTS LIST

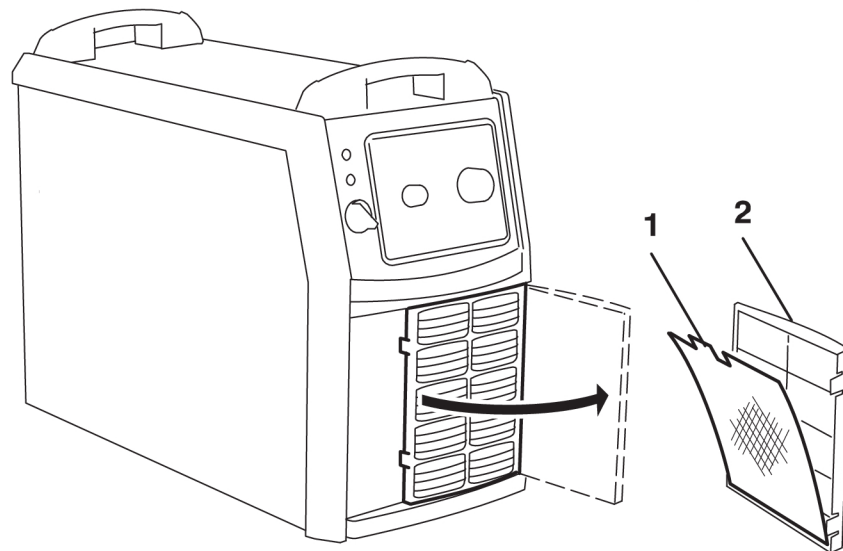
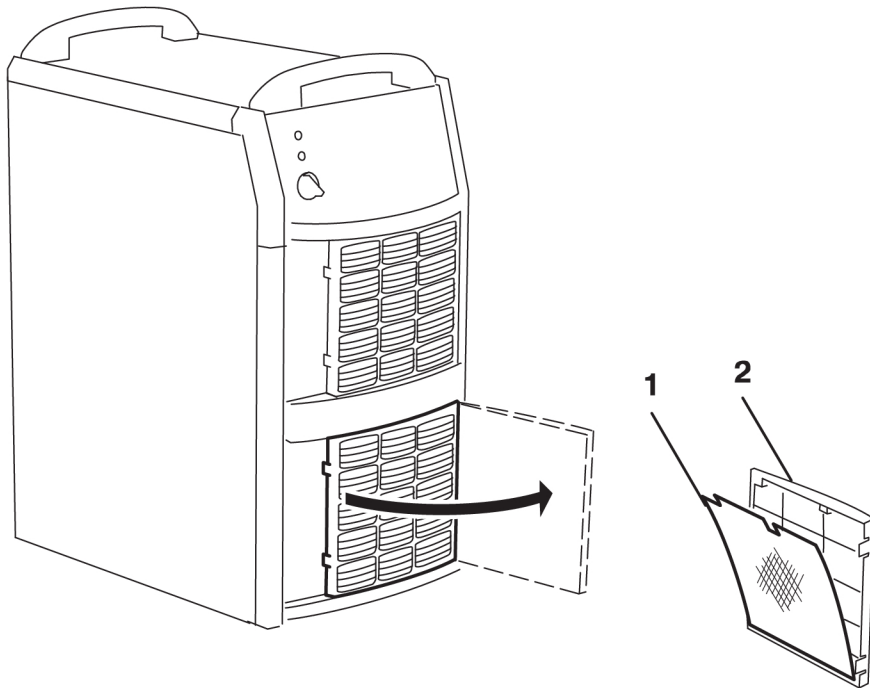

Item	Ordering no.	Denomination
1	0458 398 001	Filter
2	0458 383 991	Front grill



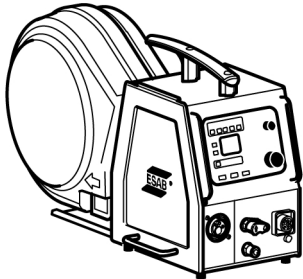

ACCESSORIES

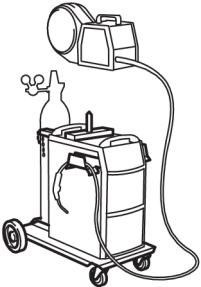
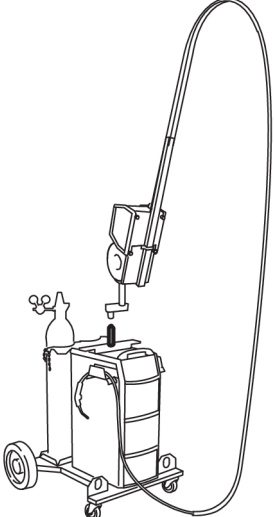
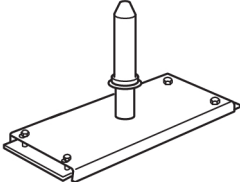

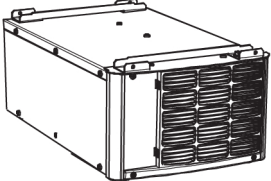
Wire feeders		
0445 800 894	RobustFeed Pulse, water-cooled	
0445 800 891	RobustFeed Pulse, water-cooled, heater, MMA outlet and flow meter included	
0445 800 892	RobustFeed Pulse, water-cooled, Push-Pull, heater, MMA outlet and flow meter included	
0445 800 887	RobustFeed U6, water-cooled, heater, MMA outlet and flow meter included	
0445 800 888	RobustFeed U6, water-cooled, Push-Pull, heater, MMA outlet and flow meter included	
0445 800 902	RobustFeed U6, water-cooled, Push-Pull, heater, flow meter, MMA outlet included and VRD activated	
0445 800 897	RobustFeed U6, water-cooled	
0445 800 898	RobustFeed U82 offshore, water-cooled, heater, Push-pull, flow meter and MMA outlet	
0445 800 899	RobustFeed U82, water-cooled	
0445 800 900	RobustFeed U82 offshore, water-cooled, Push-Pull, heater, flow meter and MMA outlet	
0445 800 901	RobustFeed U0, water-cooled	
0445 800 903	RobustFeed U82 offshore, water-cooled, Push-Pull, heater, flow meter, MMA outlet and VRD activated	
0460 526 881	Aristo® Feed 3004 U8₂, (U8 ₂ not included)	
0459 906 896	Yardfeed 2000w U6, for 200mm (8 in.) spools	

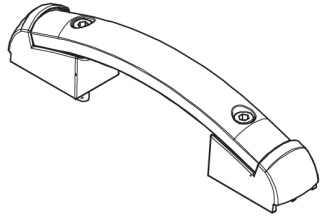
ACCESSORIES

0458 530 880	Trolley	
0458 603 880	Trolley 2 (for feeder with counterbalance device and/or 2 gas bottles)	
0558 102 236	Trolley	
0558 102 311	Kit adapter for 4004HD feeder	
0458 731 880	Guide pin	
0278 300 401	Insulating bushing for guide pin, included in trolley	
0459 145 880	Autotransformer TUA2	

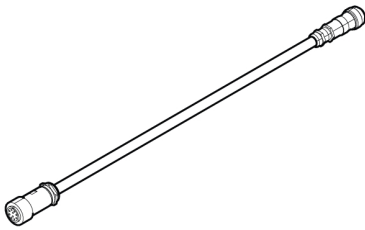
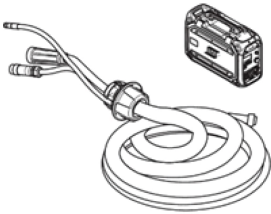
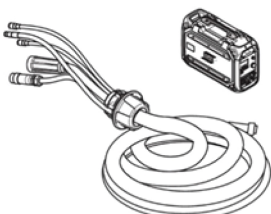
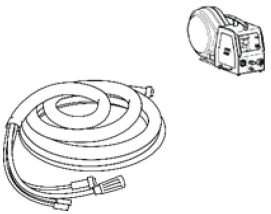
0459 307 881	Handle (1 piece) with mounting screws	
0459 491 910	Remote control adapter RA12 12 pole For analogue remote controls to CAN based equipment.	
0459 491 880	Remote control unit MTA1 CAN MIG/MAG: wire feed speed and voltage	
0459 491 882	Remote control unit M1 10Prog CAN Choice of on of 10 programs MIG/MAG: voltage deviation	
Remote control cable 4 pole - 12 pole		
0459 554 884	0.25 m	
0459 554 880	5 m	
0459 554 881	10 m	
0459 554 882	15 m	
0459 554 883	25 m	
Remote cable CAN 4 pole - 10 pole		
0459 960 883	0.25 m	
0459 960 880	5 m	
0459 960 881	10 m	
0459 960 882	25 m	
0469 960 980	5 m Heavy Duty	
0459 960 981	10 m Heavy Duty	
0469 960 982	25 m Heavy Duty	

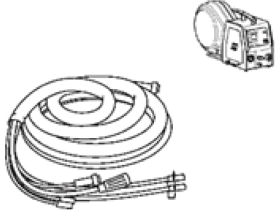
Adapter cable 10 pole - 12 pole		
0446089880	0.5 m	
0446089881	1 m	
RobustFeed U6, RobustFeed U82 and RobustFeed Pulse, Interconnection cables with pre-assembled strain relief, gas-cooled, 70 mm², 10 poles		
0446 255 880	2 m	
0446 255 881	5 m	
0446 255 882	10 m	
0446 255 883	15 m	
0446 255 884	20 m	
0446 255 885	25 m	
0446 255 886	35 m	
RobustFeed U6, RobustFeed U82 and RobustFeed Pulse, Interconnection cables with pre-assembled strain relief, water-cooled, 70 mm², 10 poles		
0446 255 890	2 m	
0446 255 891	5 m	
0446 255 892	10 m	
0446 255 893	15 m	
0446 255 894	20 m	
0446 255 895	25 m	
0446 255 896	35 m	
Aristo® Feed 3004 Interconnection cables, gas-cooled, 70 mm², 10 poles		
0459 528 780	1.7 m	
0459 528 781	5 m	
0459 528 782	10 m	
0459 528 783	15 m	
0459 528 784	25 m	
0459 528 785	35 m	
Aristo® Feed 3004 Interconnection cables, gas-cooled, 95 mm², 10 poles		
0459 528 980	1.7 m	

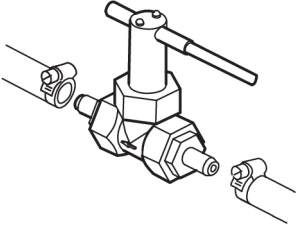
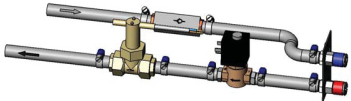
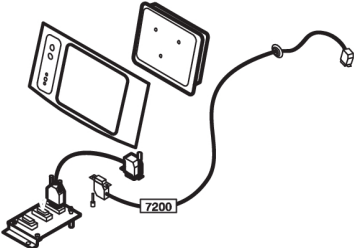
Aristo® Feed 3004 Interconnection cables, water-cooled, 70 mm², 10 poles		
0459 528 790	1.7 m	
0459 528 791	5 m	
0459 528 792	10 m	
0459 528 793	15 m	
0459 528 794	25 m	
0459 528 795	35 m	
Aristo® Feed 3004 Interconnection cables, water-cooled, 95 mm², 10 poles		
0459 528 990	1.7 m	
0459 528 991	5 m	
0459 528 992	7 m	
0459 528 993	15 m	
0459 528 994	25 m	
0700 006 897	Return cable 5 m, 95 mm²	
0456 855 880	Water flow guard 0.7 l/min	
0461 203 880	Water return flow guard Mech 7 m	
0459 579 880	MMC kit for power source Mig	

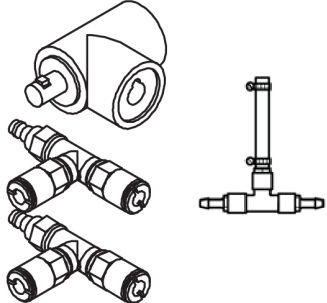
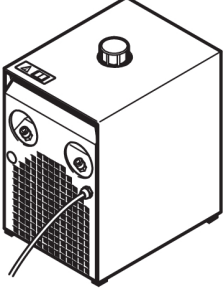
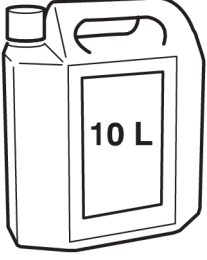
<p>0459 546 880</p>	<p>Connection set for connection of two wire feed units</p>	
<p>0414 191 881</p>	<p>Cooling unit OCE2H</p>	
<p>0465 720 002</p>	<p>ESAB ready mixed coolant (10 l / 2.64 gal) Use of any other cooling liquid than the prescribed one might damage the equipment. In case of such damage, all warranty undertakings from ESAB cease to apply.</p>	



A WORLD OF PRODUCTS AND SOLUTIONS.



For contact information visit esab.com

ESAB AB, Lindholmsallén 9, Box 8004, 402 77 Gothenburg, Sweden, Phone +46 (0) 31 50 90 00

manuals.esab.com

